

## Installation Overview

- Ideal installation of a Zacklift is as close to the rear axle as possible. Be sure to allow enough room for clearances.
- The factory advises that all chassis have a subframe in addition to a mainframe, an inadequate subframe should be replaced with at least 4" x 6" x 3/8" rectangular steel tubing.
- If your truck frame is aluminum all attachments must be bolted. Make sure all bolts are of adequate strength.
- Before installation of your Zacklift you will need to box the mainframe and subframe of your truck.
- Tack-weld or bolt all mounting parts temporarily ( *to check for proper function and clearance* ) before final welding or bolting.
- It is advised to work on solid level ground during the entire installation. Make sure the truck frame and or wrecker body is level before starting installation.

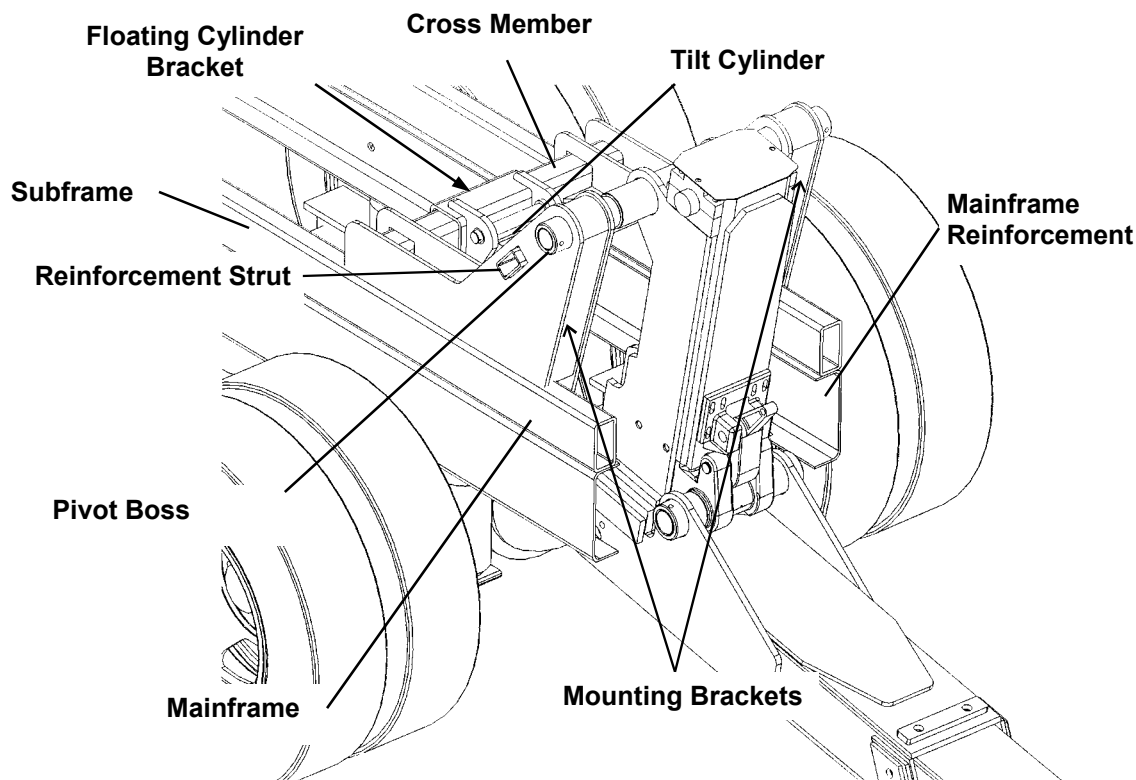

# Preparing wrecker body

1. Before starting the installation remove or protect any air lines, hydraulic lines, or wiring.
2. To begin installation remove a section of the wrecker deck approximately 36" wide by 50" deep see fig. 1-A This allows access for reinforcement of the main frame, inspection and possible replacement or reinforcing of the subframe, and installation of the mounting ears and crossmember. In some applications you will need to relocate the winch control rods to fully recess the Zacklift. This will be covered in section "E"
3. Cut the tailboard to allow for recessing of the Zacklift. Remember the object is to mount the unit as close to the rear axle as possible for the best weight distribution. The cutout should be centered on the tailboard and have a minimum of 1/2" clearance on both sides of the Zacklift main body.
4. With the tailboard and deck cut out you now have access to reinforce or "box" the mainframe and subframe. Use at least 3/8" material (*not supplied*) This should be done in such a way to tie the mainframe and subframe together. The reinforcement should extend from the tailboard to well in front of the rear axle.

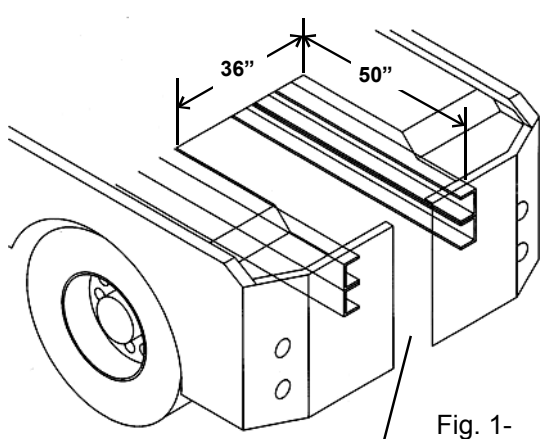

Tailboard cutout 1/2" clearance on both sides of Zacklift mainbody

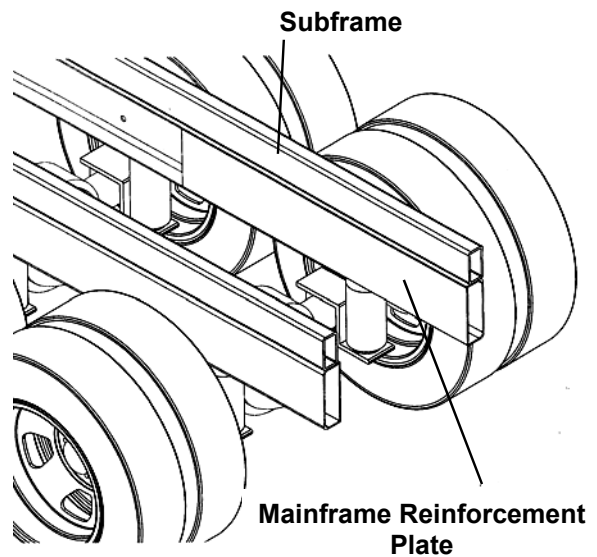

## Preparing the bare frame

1. In almost all cases the rear crossmember must be removed, so as to mount the Zacklift as close to the rear axle as possible for the best weight distribution.
2. A subframe must be installed prior to installation of the Zacklift. The subframe should be made of at least 4 x 6 x 3/8" rectangular tubing and should run from the rear end of the frame to at least in front of the rear axles. Ideally the subframe should run all the way to the cab. The subframe should be connected to the mainframe by using plates as in fig. 2-A Welding the subframe to the mainframe is not recommended
3. It is also recommended to reinforce or "box" the mainframe using at least 3/8" plate (*not supplied*) see fig. 2-A

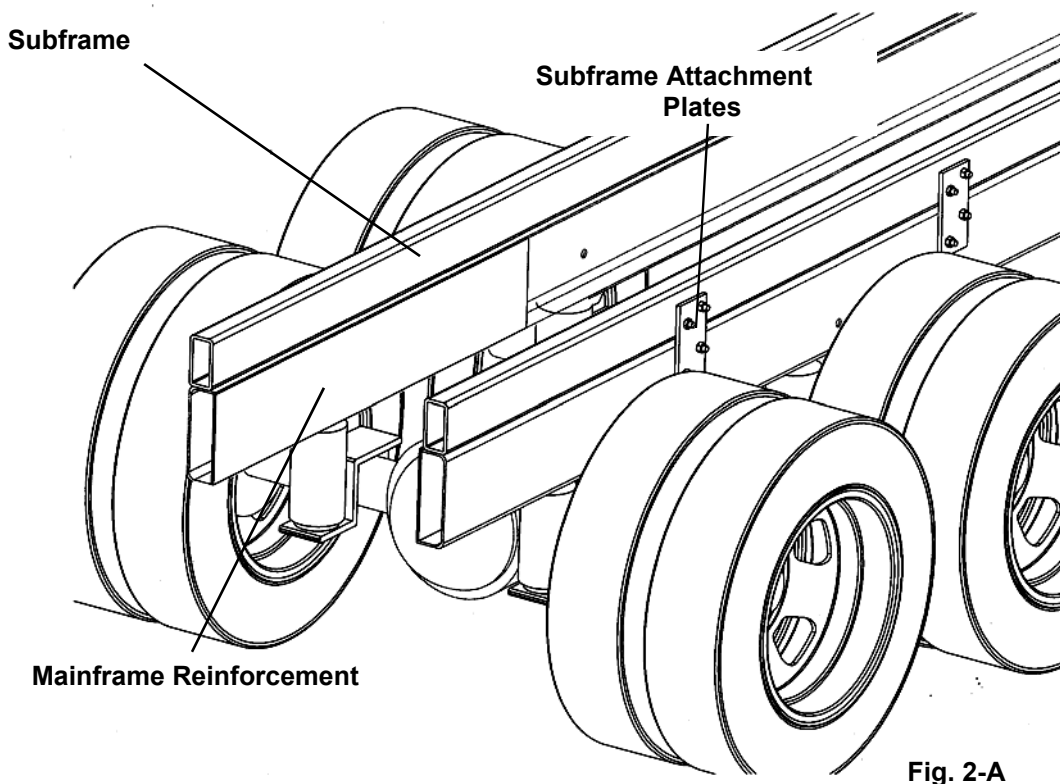
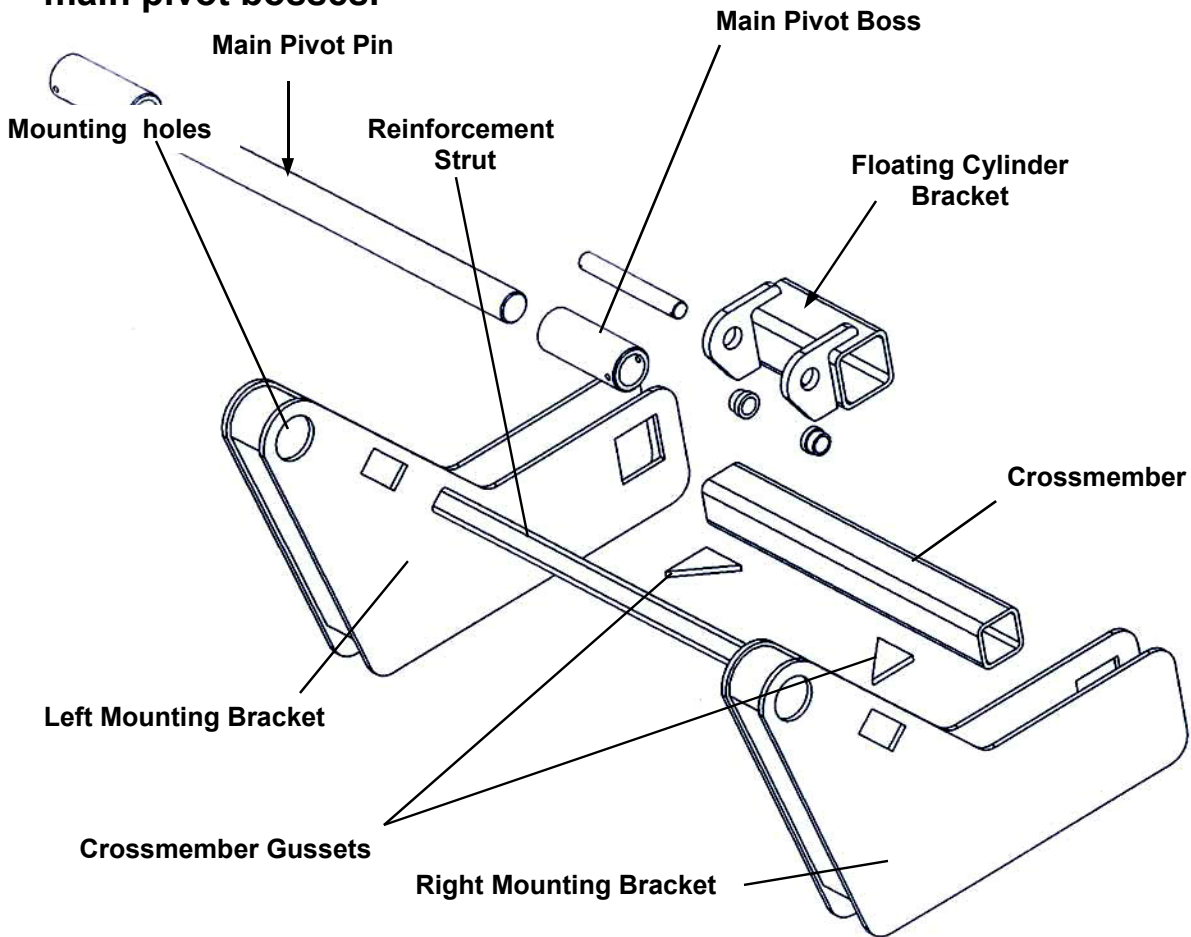

Fig. 2-A

# Mounting System

1. The mounting system is made up of six main components, two mounting brackets one left one right, the reinforcement strut, the tilt cylinder crossmember, the crossmember gussets, and the main pivot bosses.



2. Install the first mounting bracket by sliding the bracket over the subframe. The inside plate of the bracket should slide down the inside of the subframe like a saddle. In some cases the space between the plates is too wide and must be shimmed by using various thickness of sheet metal to increase the width of the subframe (not provided). It may be necessary to trim mounting brackets to avoid obstruction. Always trim as little as possible to allow as much “saddle” to remain as possible. It may be necessary to trim the web between the plates of the mounting brackets so as to slip brackets over frame & achieve correct mounting height. Always trim as little as possible.

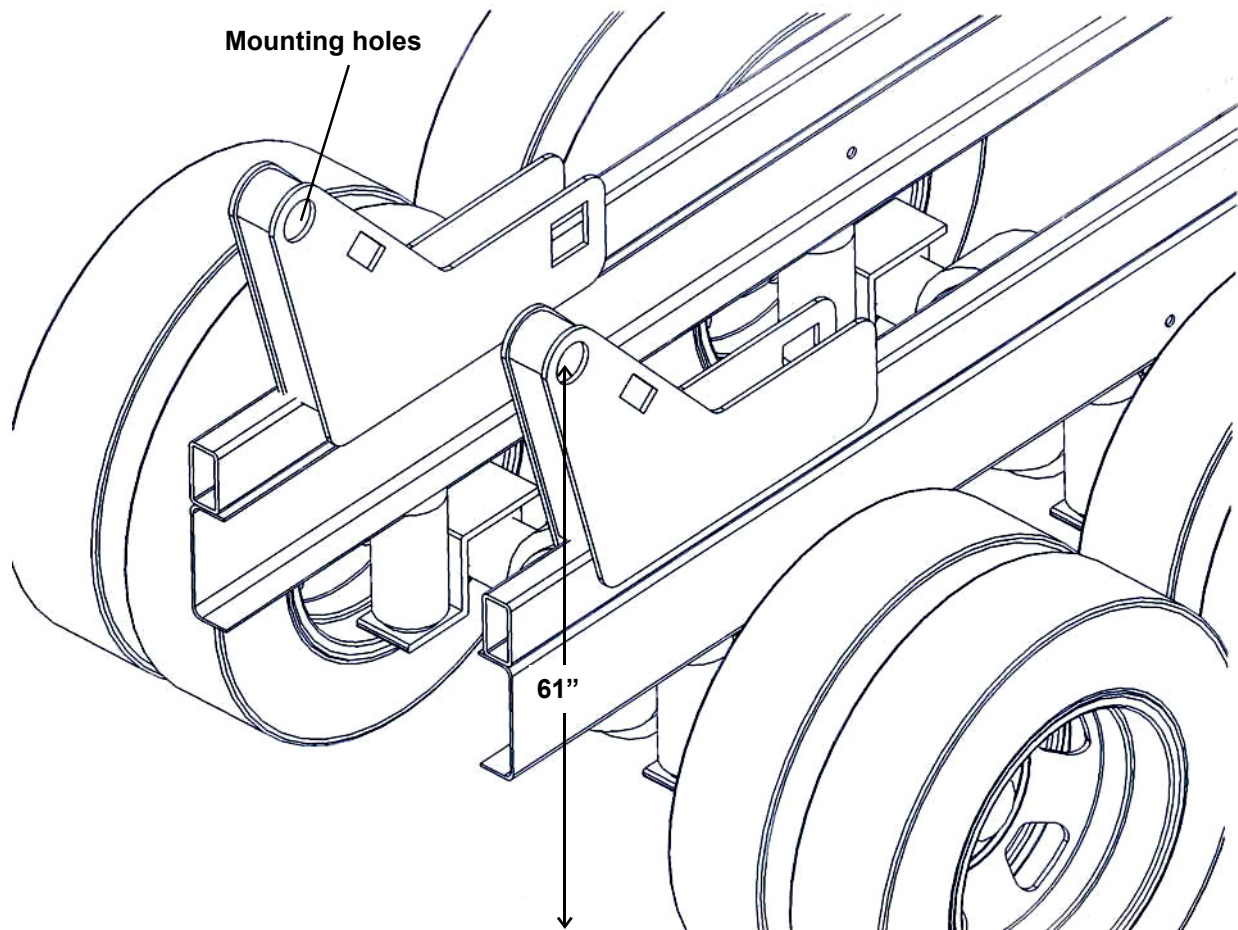

3. The object of trimming the mounting brackets is to put the center of the main pivot point exactly 61" from ground level. This puts the Zacklift at the correct working height and allows for a full range of motion.
4. After trimming and shimming the mounting brackets for the correct height, clamp them into position. The bottom of the inside plate should be level with the ground and the distance from the rear axle housing to the main pivot point should be at least 11". Reposition and trim as necessary. Recheck the clearances when you temporarily mount the Zacklift and before final welding.
5. After achieving the required 61" pin height, position and fit the tilt cylinder cross member. In some cases the length of the cross-member will have to be trimmed to fit in between the subframe. It is important to trim both sides equally.

**IMPORTANT!!!**  
Check all clearances before final welding!!

6. In some cases it may be necessary to remove and reposition one or both of the mounting brackets to install the crossmember into the mounting holes. Once the crossmember is in position and the mounting brackets are in place, tack weld the crossmember and mounting brackets to the subframe. Be sure the mounting brackets are secure enough to hold the weight of the Zacklift for temporary mounting.
7. Floating cylinder bracket must not be welded to crossmember. Welding floating cylinder bracket may result in damage to tilt cylinder.
8. Position the main pivot bosses in the mounting bracket pivot holes using the main pivot pin for alignment. There must be 20-1/8" between pivot bosses and they must be centered. Carefully tack weld them in place securely enough to temporarily hold the weight of the Zacklift.
9. Position the reinforcement strut in position on the mounting brackets. Trim to length and tack weld until final welding and assembly.

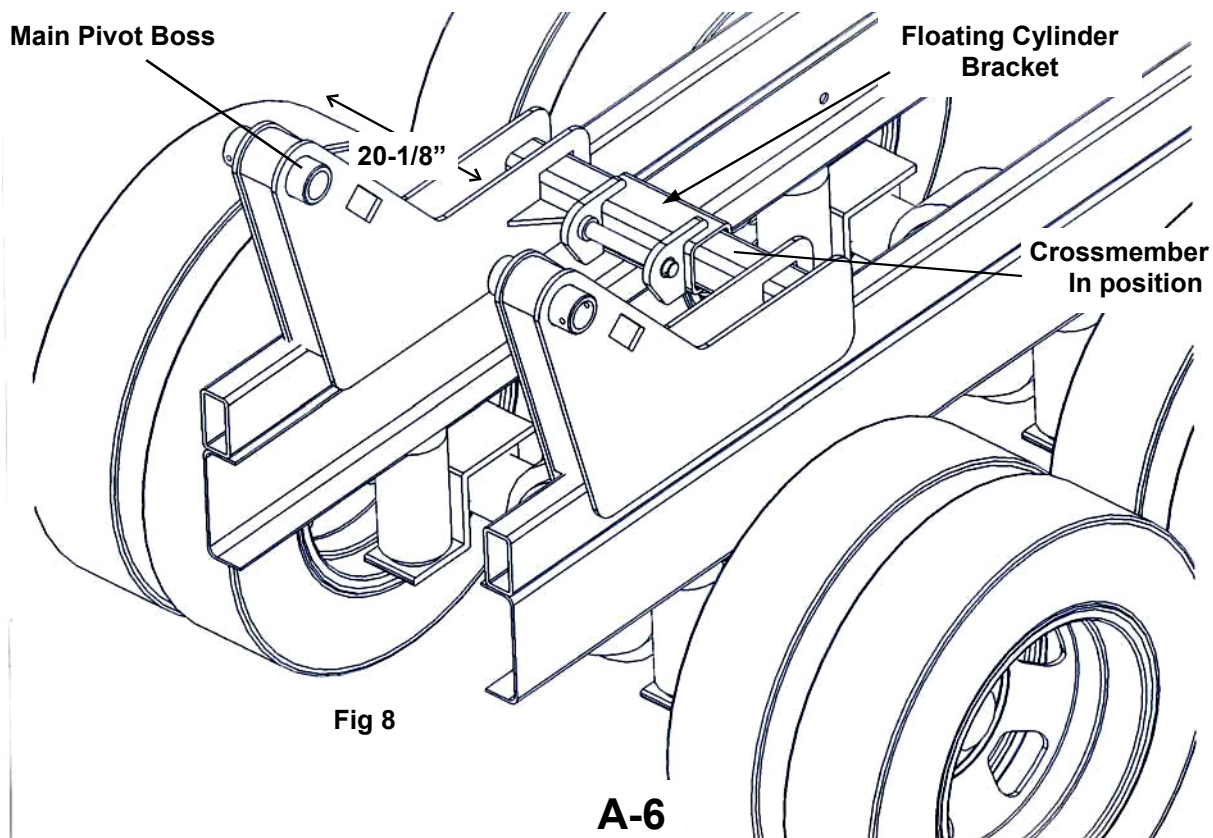

10. Temporarily mount the Zacklift and the tilt cylinder to the mounting brackets and crossmember. Check for proper clearances. Pay close attention to where the Zacklift is in relation to the rear axle housing, allowing for spring deflection, and where the hydraulic fittings will be located on the outer horizontal. You may want to do more trimming of the tailboard at this time.

11. Remove the Zacklift from the mountings and complete the final welding of the mounting brackets, crossmember, to frame (Not Floating Cylinder Bracket) reinforcement strut and all gussets. When welding in the main pivot bosses you must keep them aligned. It is helpful to keep the pivot pin in place during this process

12. The crossmember must be securely reinforced with gussets to the subframe. This bracing is critical to support the weight of the vehicle in tow on the crossmember.

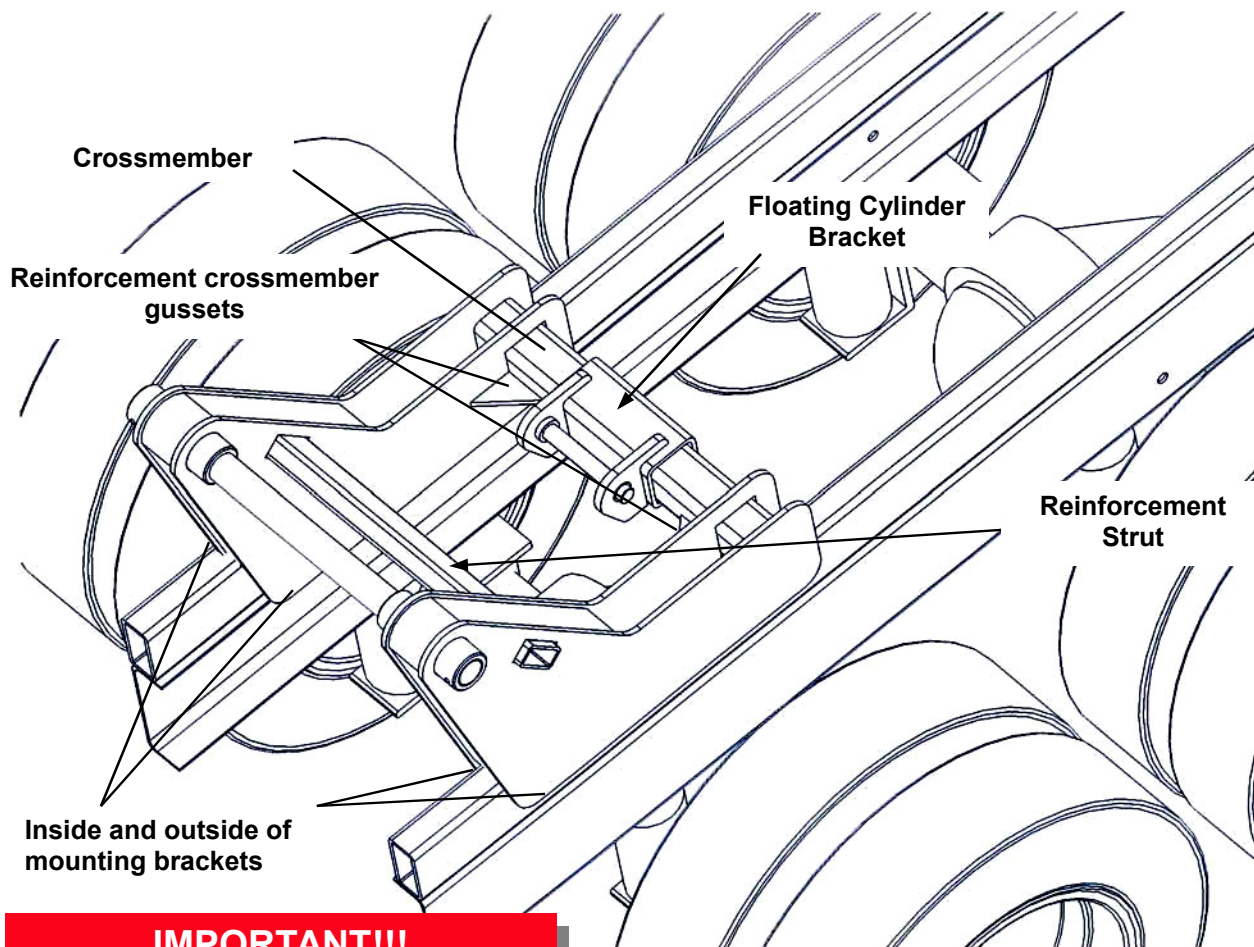

**IMPORTANT!!!**  
Do not weld floating cylinder  
bracket to crossmember!!